

URBAN SKETCHING II 2026



Overview

- Day 1 Materials / Refresher Perspective
- Day 2 Warm Up / Venice: Domes, Bridges, Windows
- Day 3 Warm Up / Boats
- Day 4 Warm Up / Japan: Temples and Shrines
- Day 5 Warm Up / Drawing People
- Day 6 Warm Up / Fun with Ink

WHAT IS URBAN SKETCHING?

- Nonprofit Organization formed in 2007:
<http://www.urbansketchers.org/>
- A Global Community of Artists Who Practice and Share On-Location Drawing
- Victoria Local Chapter on Facebook

WHAT IS URBAN SKETCHING?



Kiah Kiean



João Paulo
Albergaria

WHAT IS URBAN SKETCHING?



Marc Taro Holmes



Simone Ridyard

WHAT IS URBAN SKETCHING?

Victoria Urban Sketchers
Works by: Cheryl, Inge,
Lindsay

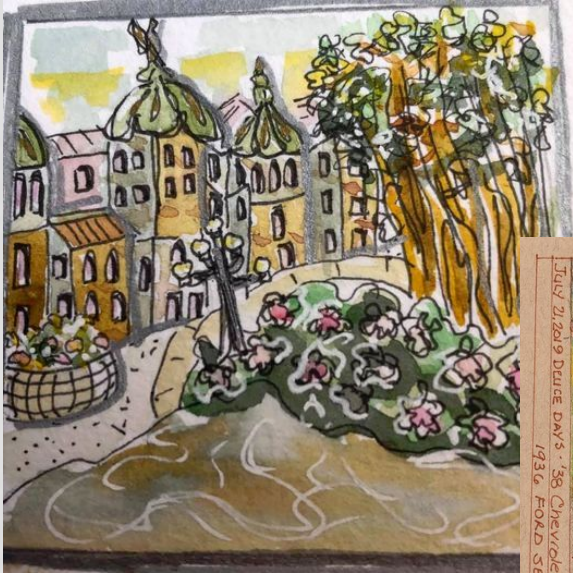

WHAT IS URBAN SKETCHING?



**Urban Sketchers
Victoria**

Victoria Urban Sketchers
Public group · 668 members

[+ Invite](#) [Share](#) [Joined](#) [▼](#)

[Discussion](#) [People](#) [Events](#) [Media](#) [Files](#) [Q](#) [...](#)

Upcoming events [Find events](#) [Create event](#)

Sketch Butterfly Gardens
This Saturday at 10 AM
Created by Sophie Oliveau-Moore

[Interested](#) [Going](#) [Invite](#) [Share](#) [...](#)

Sketch the Saanich Centennial Library
Sat, Jan 31 at 10 AM
Created by Sophie Oliveau-Moore

REFERENCES

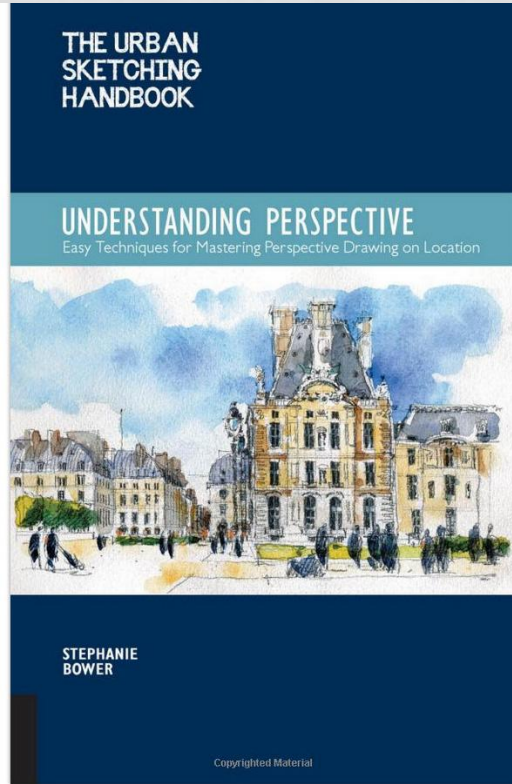

Books by:
Marc Taro Holmes (right)
Stephanie Bower (left)

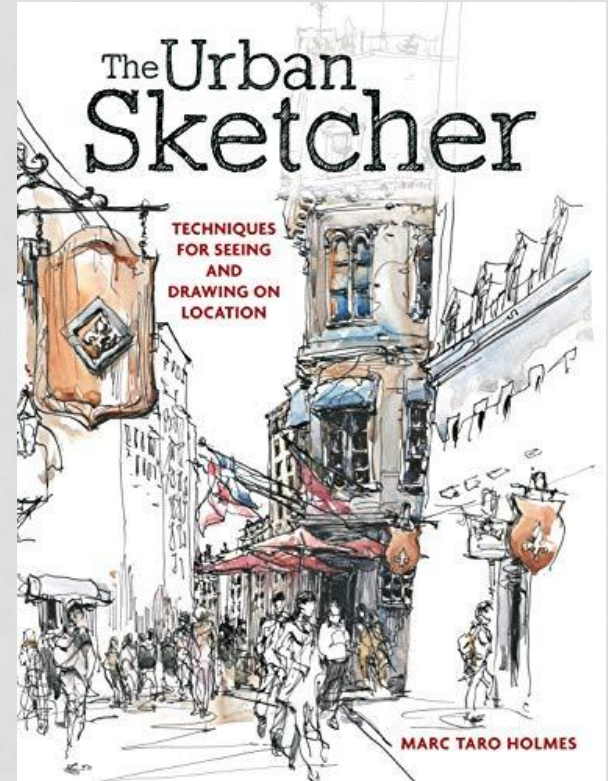

MY URBAN SKETCHING

Pencil:

As little as possible

Ink:

As much as needed

Watercolour:

As much as necessary



WHY INK ?

- Permanence
- Easy to transport
- Value range

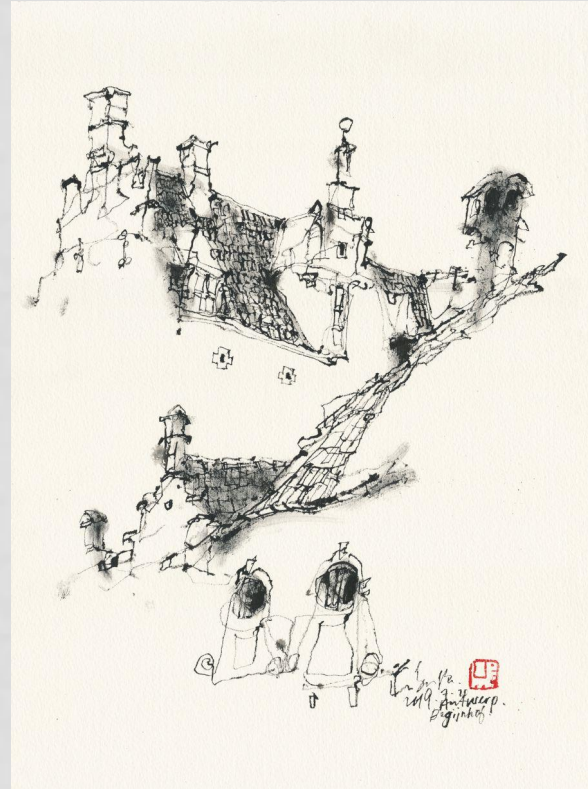

Kiah Kiean

MATERIALS

- Go light, less is more
 - All equipment can fit in a mid-sized backpack
- Be comfortable, be flexible
 - Chair, sun hat
- Plan ahead
 - Local art supply (paper)
 - Water supply etc.



MATERIALS

- Comfort



MATERIALS

- Sketching Tools 1

- HB Pencil
- Ink Pen
 - Uni-Ball Vision Fine
 - Staedtler Lumocolor Permanent F
 - Kuretake Brush Pen
 - Pentel Art Brush
- Eraser



MATERIALS

- Sketching Tools 3
 - Fountain pen
 - Problem: Most waterproof inks will clog your fountain pen, so only use:
 - Noodler's Bulletproof
 - **Platinum Carbon Ink**
 - De Atramentis Ink



Sketchbooks

- Watercolour Books and Pads
 - Moleskine
 - Hahnemuehle
 - Make your own book

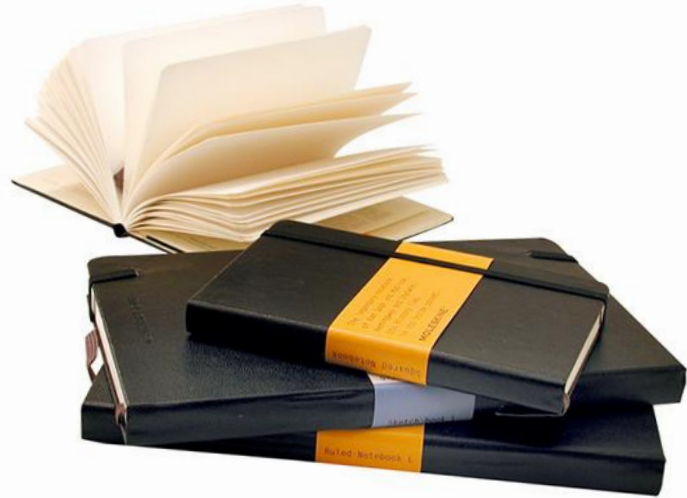

PAPER

- Cheap sketchbook for layout and doodles:
 - Opus
 - Strathmore etc.



PAPER FOR WATERCOLOUR 1

- Sheets 100% Cotton
- Hot Pressed, Cold Pressed (NOT), Rough
 - Arches, Waterford Sanders, Fabriano Artistico, Opus Finest
- Full sheet (30 x 22 in)
- Half sheet (22 x 15 in) or (30 x 11)
- Quarter sheet (11 x 15 in)
- Exotic formats

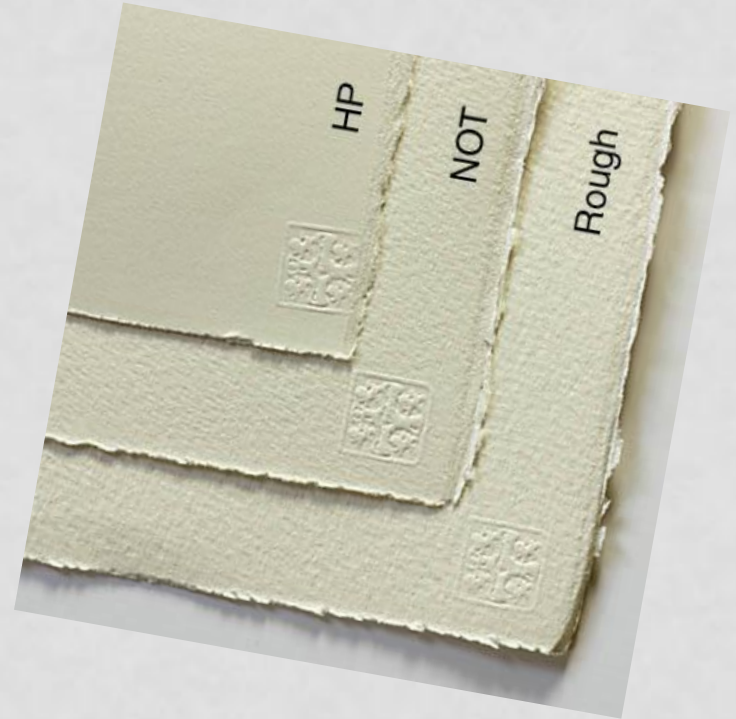

PAPER FOR WATERCOLOUR 2

- Weight
 - 90 lb (200g)
 - 140 lb (300g)
 - 300 lb (600g)

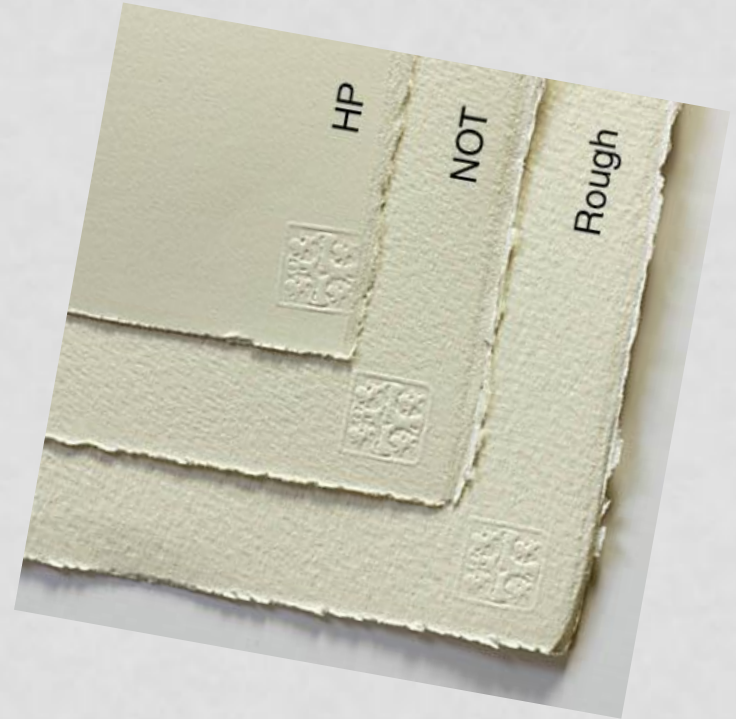

PAPER FOR WATERCOLOUR 3

- Watercolour Blocks
 - Glued on outside
 - Buy 100% Cotton!



Warm Up

- Warm up on cheap paper 2 x 5 minutes

PERSPECTIVE

Linear Perspective



LINEAR PERSPECTIVE

Straight on view
“Elevation”

Horizontal lines
remain horizontal
in drawing

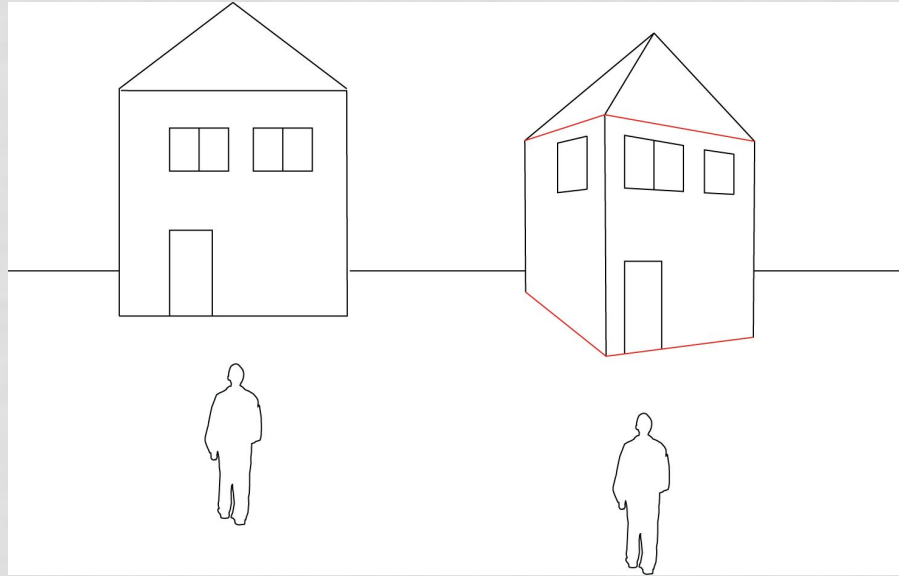

Angled View
“Perspective”

Horizontal lines
appear tilted

PERSPECTIVE

“Tracing”

- Real World
- Photo



PERSPECTIVE

Practice



LINEAR PERSPECTIVE

Only use lines
that are parallel
to the ground!!!
“True horizontal”

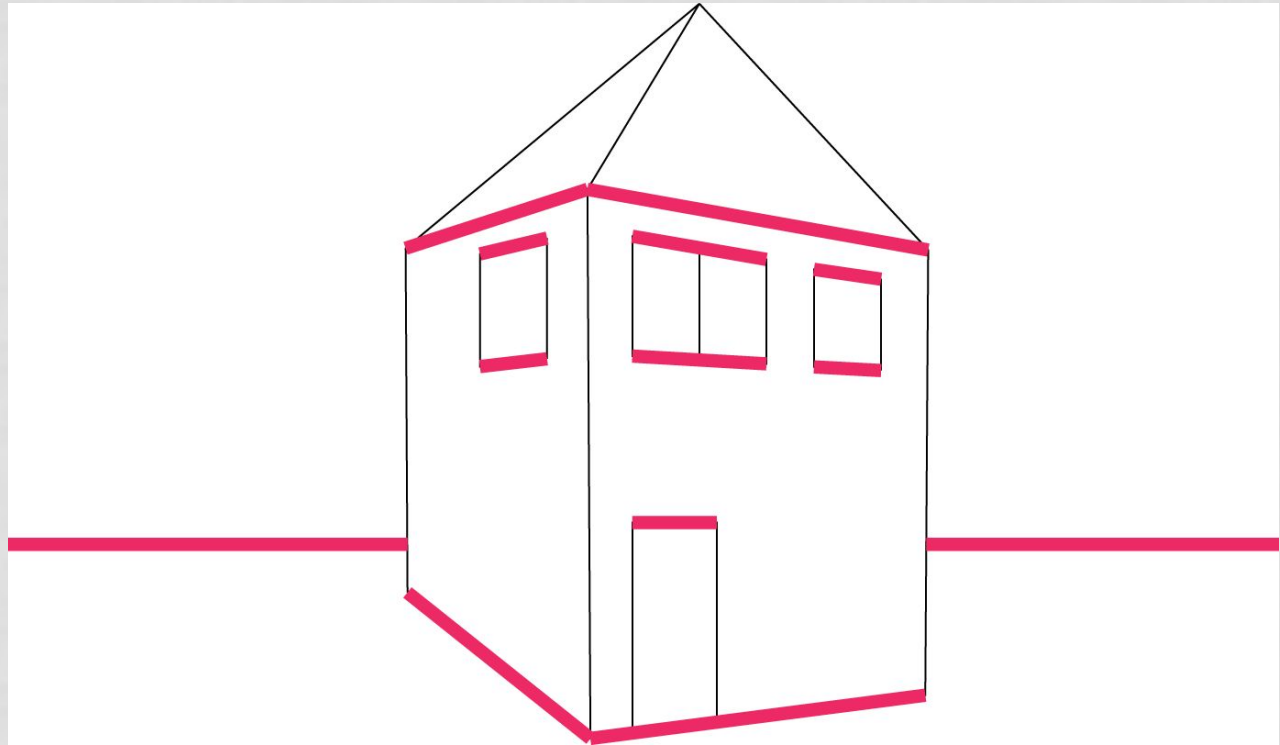

LINEAR PERSPECTIVE

Straight on View
“Elevation”

Lines parallel to the ground
remain horizontal on paper



LINEAR PERSPECTIVE



Angled View
“Perspective”

Lines parallel to the
ground (true
horizontal) appear
tilted on photo and
paper

PERSPECTIVE

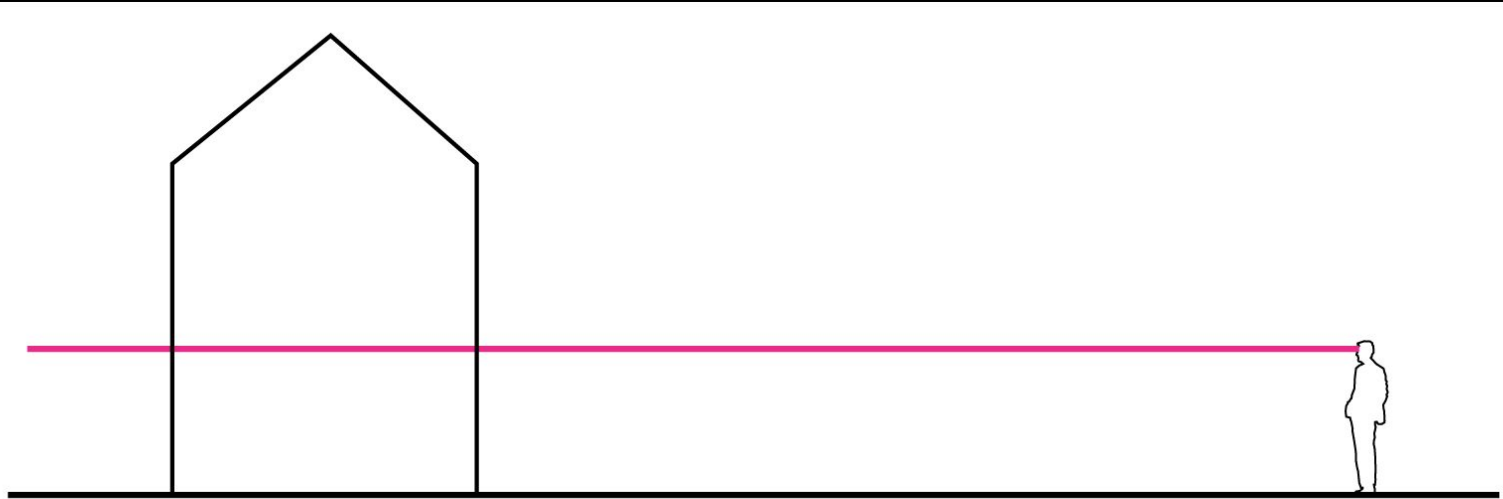

Eye Level=Horizon Line

PERSPECTIVE

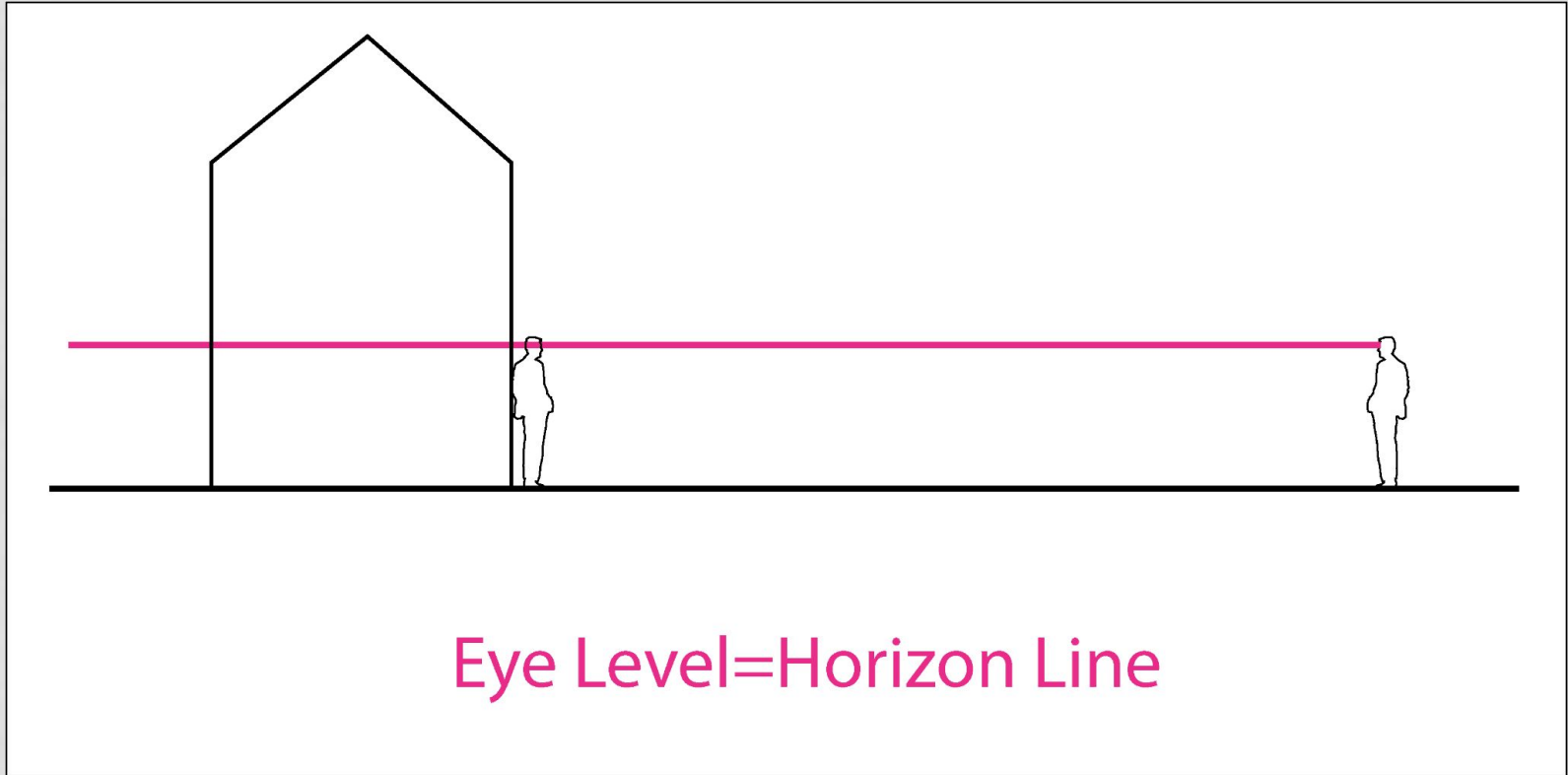

Eye Level=Horizon Line

PERSPECTIVE

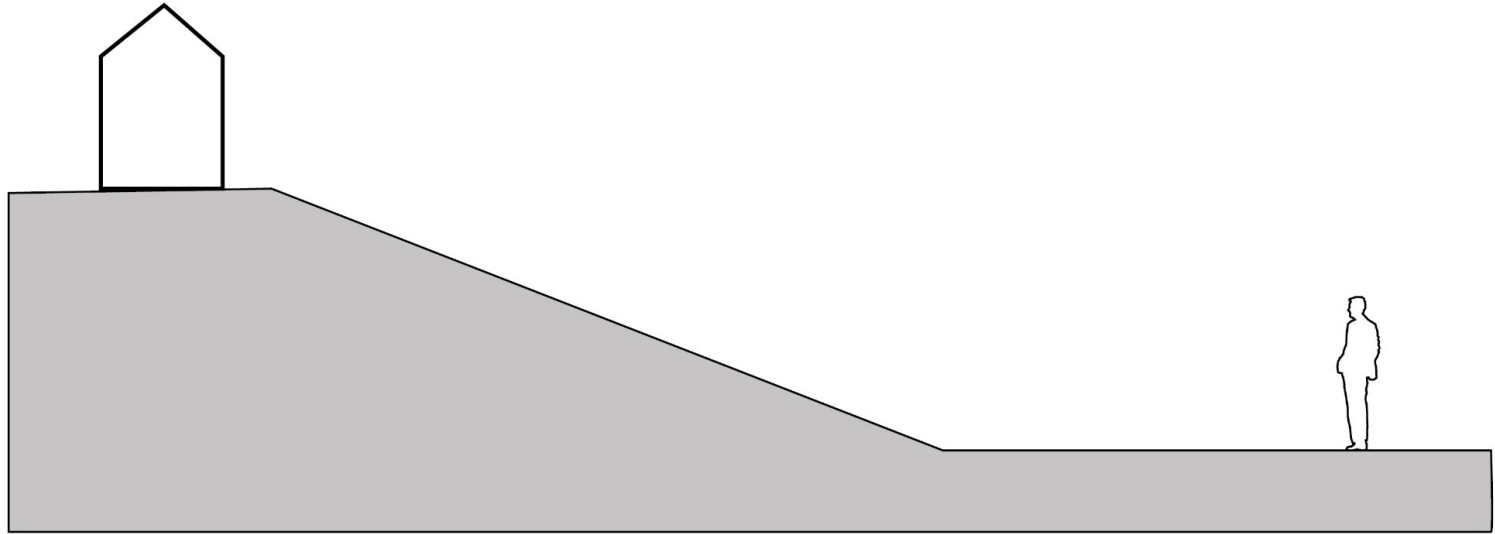

Eye Level=Horizon Line

PERSPECTIVE

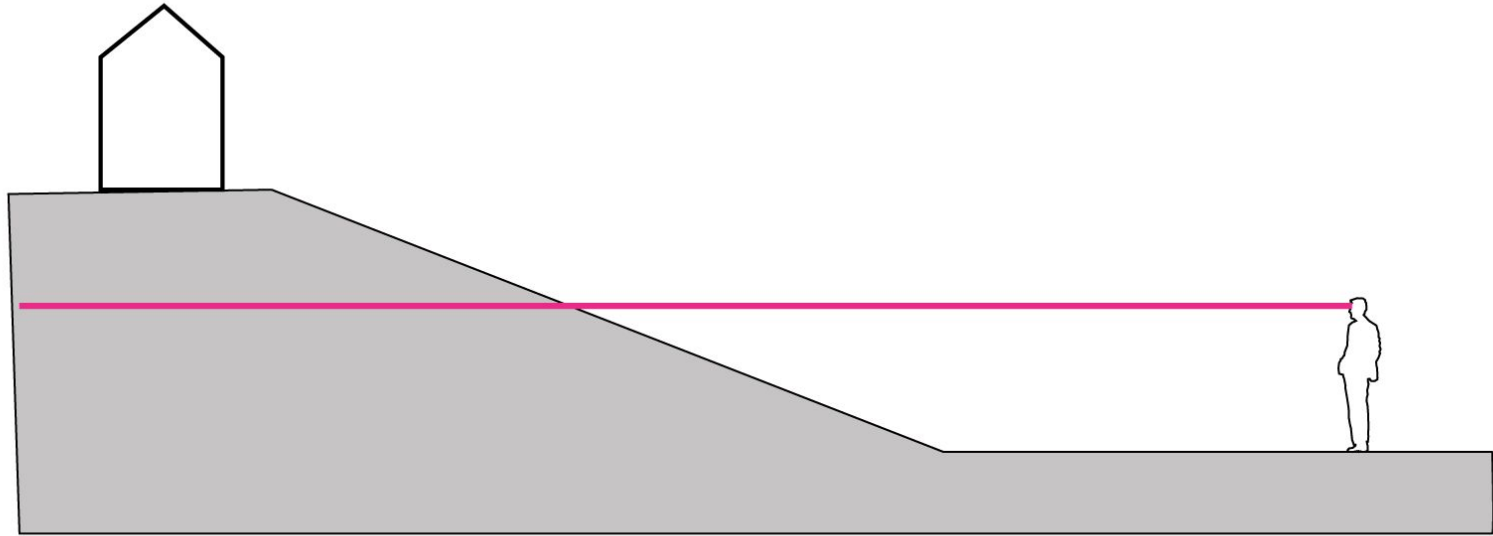

Eye Level=Horizon Line

PERSPECTIVE

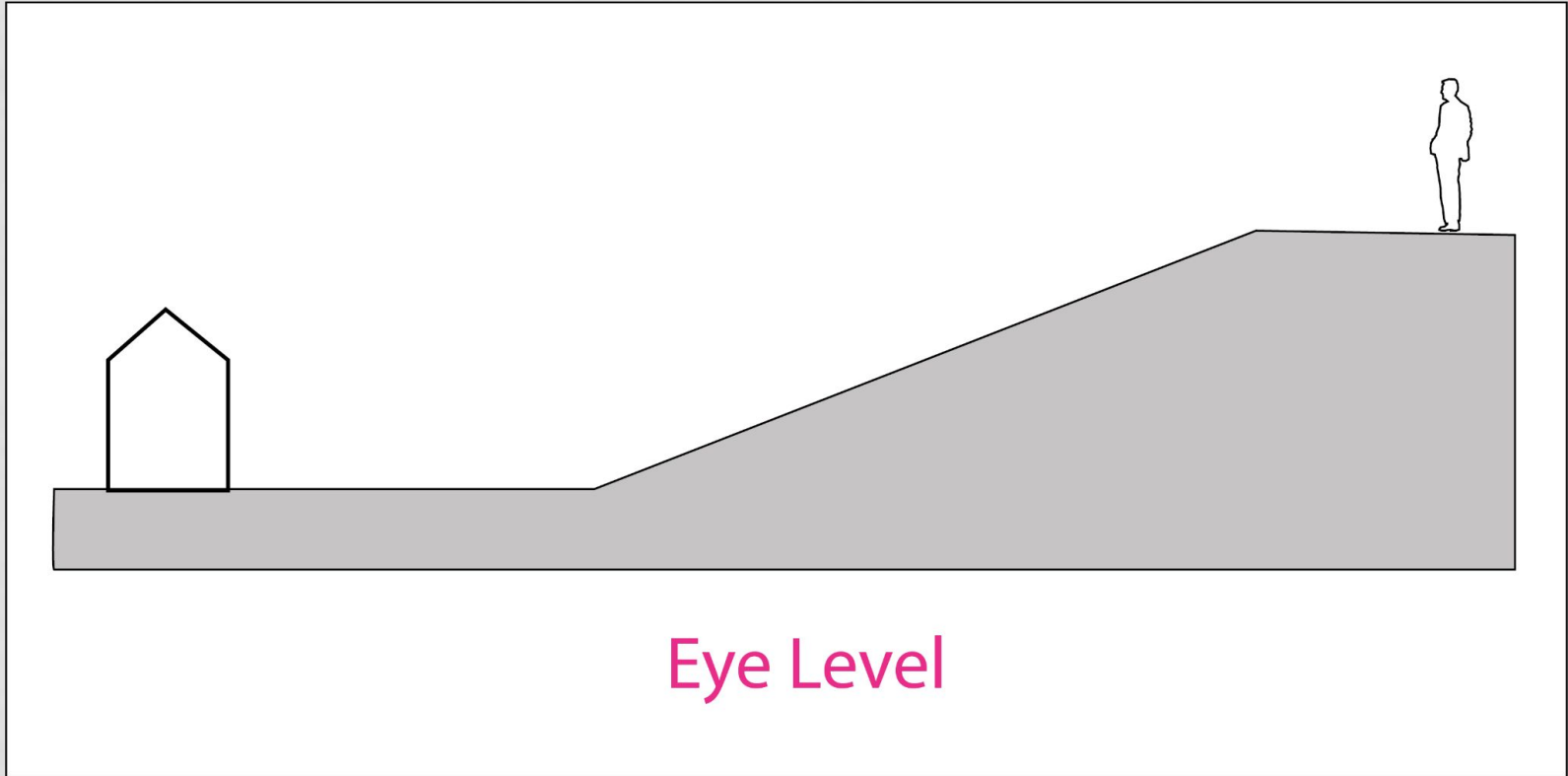

PERSPECTIVE

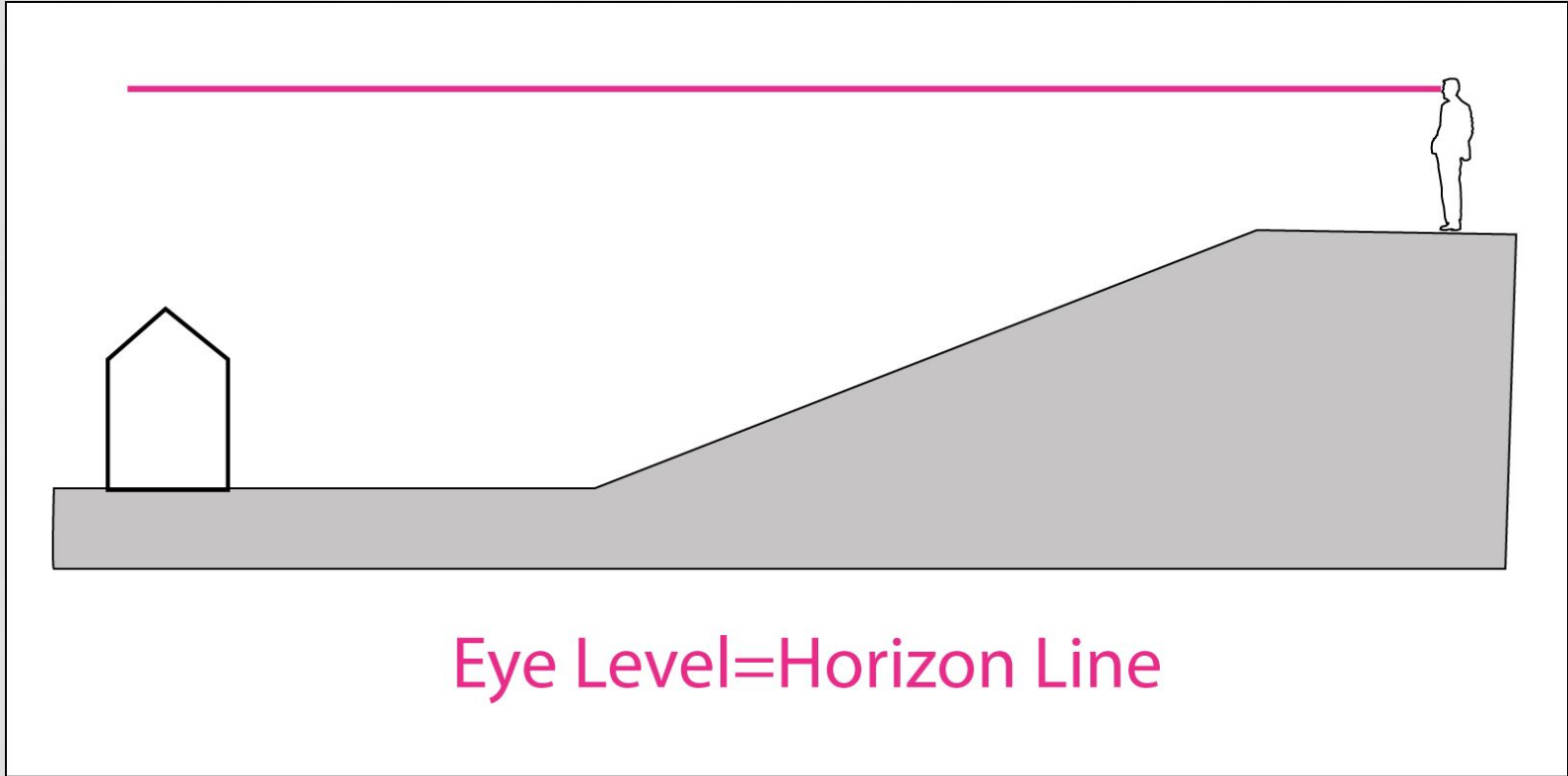

PERSPECTIVE



PERSPECTIVE



PERSPECTIVE



PERSPECTIVE



A
B
C

PERSPECTIVE



PERSPECTIVE

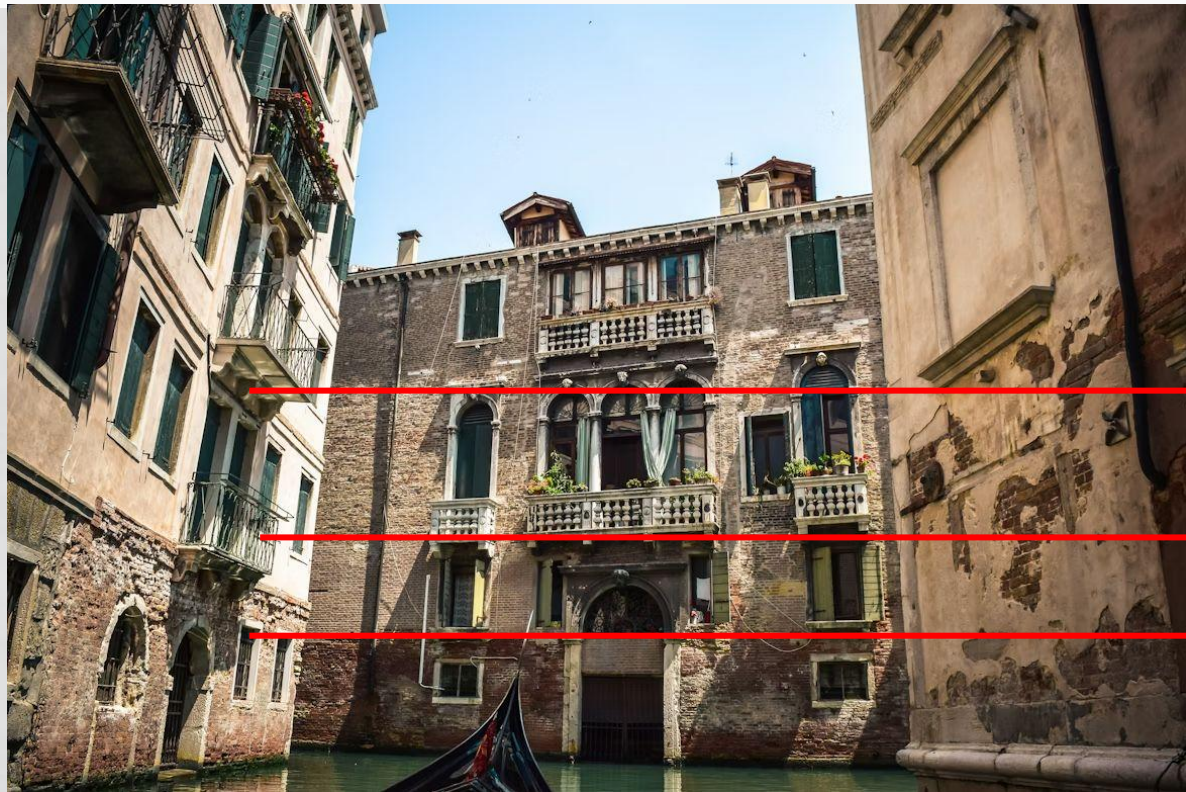

A

B

C

PERSPECTIVE



A

B

C

PERSPECTIVE



PERSPECTIVE

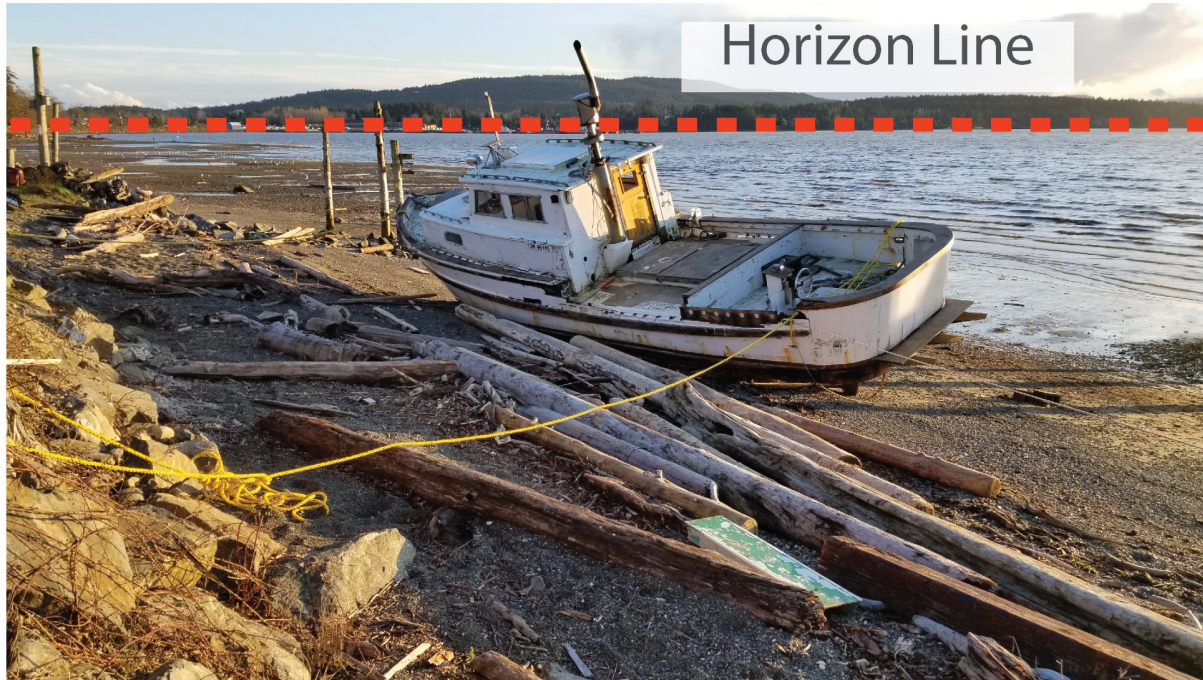

PERSPECTIVE

Horizon Line ?



PERSPECTIVE EXERCISE 2



Eyelevel?

PERSPECTIVE EXERCISE 2

Eyelevel / Horizon Line



PERSPECTIVE EXERCISE 2



PERSPECTIVE EXERCISE 2



PERSPECTIVE EXERCISE 2



Eyelevel / Horizon Line

PERSPECTIVE



What is the process? (1) Find Eye Level

PERSPECTIVE



Eye Level = Horizon Line

PERSPECTIVE

2 - Point perspective

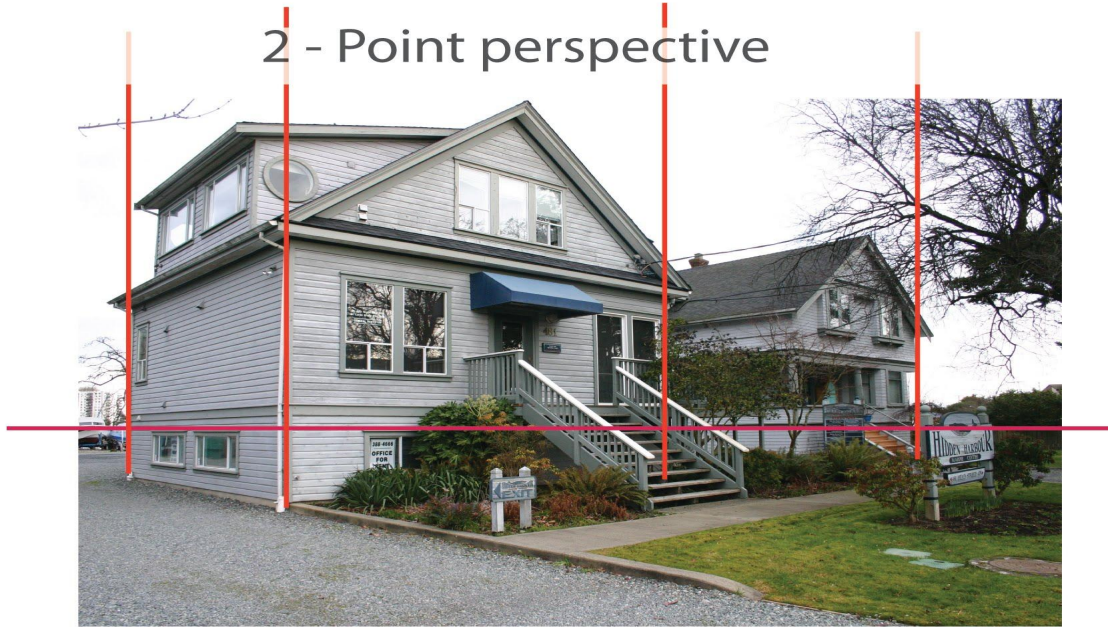

Simplification: Vertical Lines parallel

PERSPECTIVE



PERSPECTIVE



PERSPECTIVE

Vanishing Points



PERSPECTIVE

Vanishing Points



Second vanishing point

PERSPECTIVE



PERSPECTIVE



Parallel faces have the same Vanishing Point!

PERSPECTIVE EXERCISE 1

- Which lines are truly horizontal?
- Find Vanishing Points
- Construct doors and windows for each side

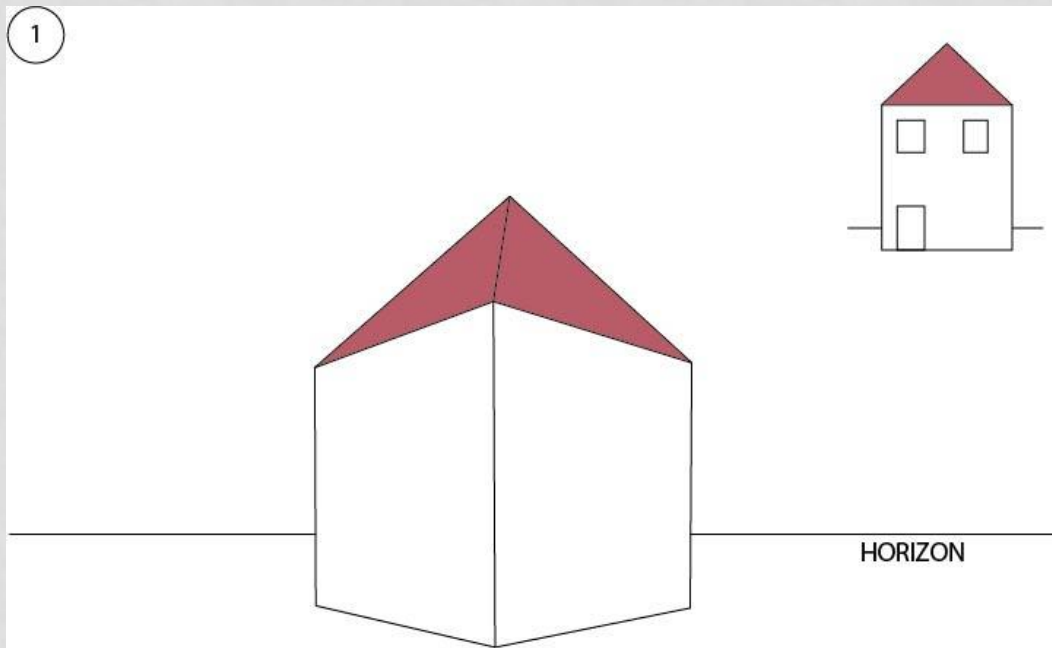

PERSPECTIVE EXERCISE 2

- What if the Vanishing Point is off the page?

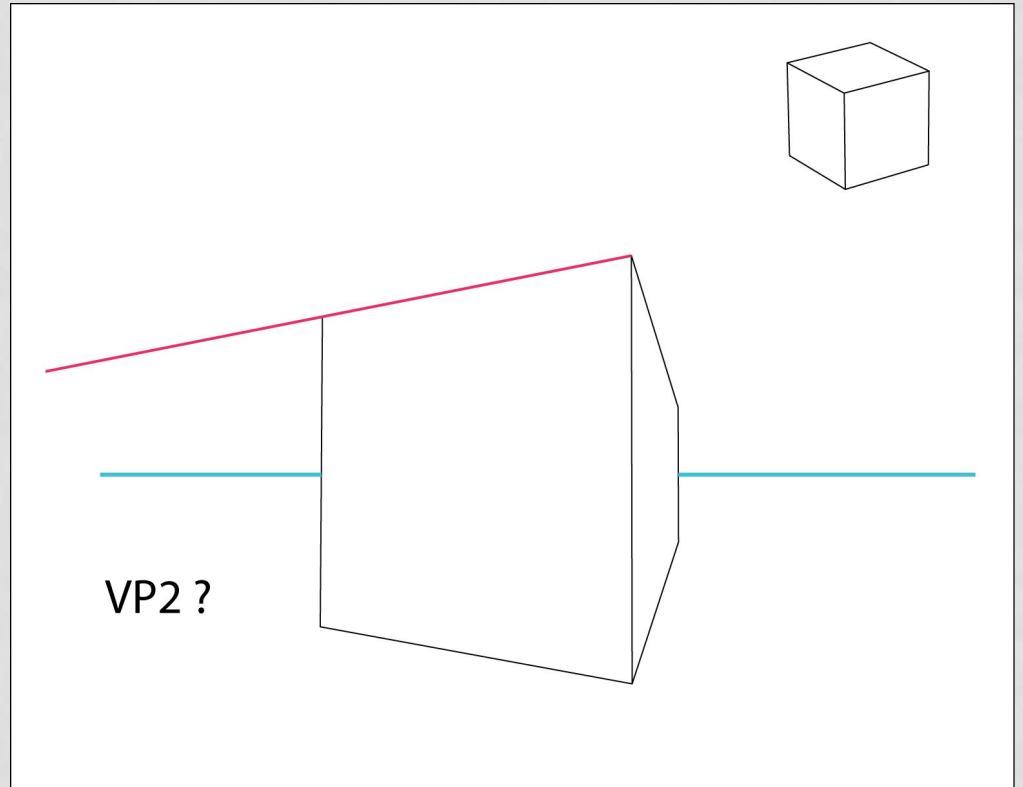

PERSPECTIVE EXERCISE 2

- What if the Vanishing Point is off the page?

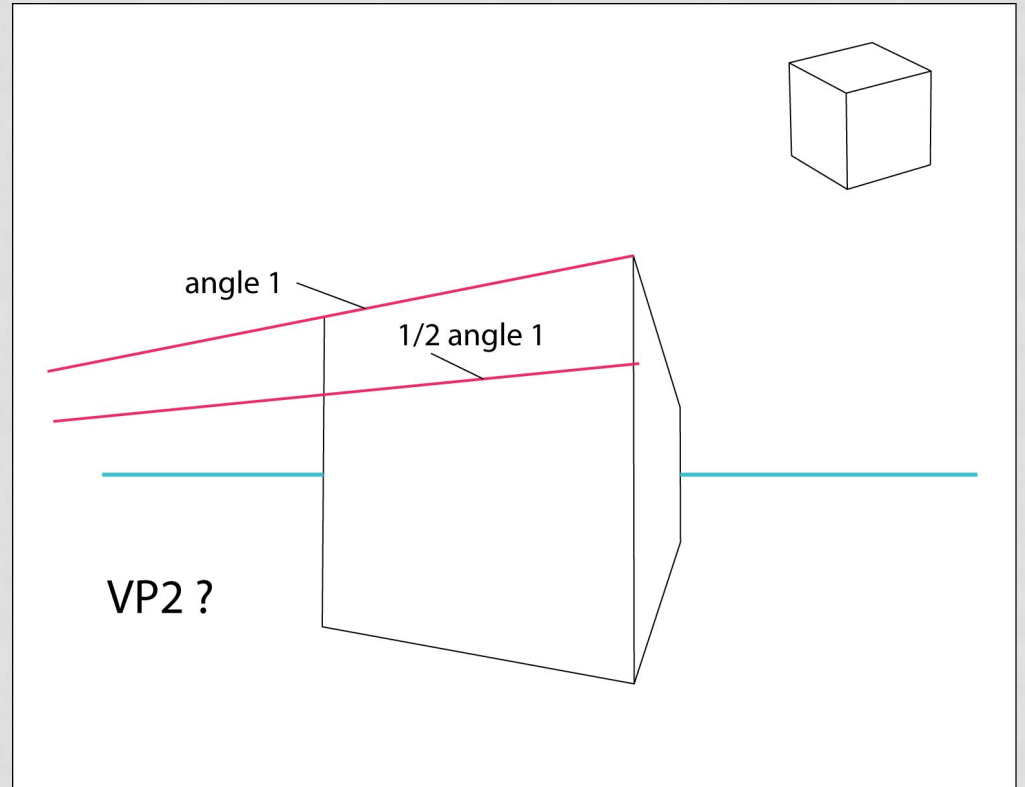

PERSPECTIVE

Where is the
Horizon Line
/ Eye Level?



PERSPECTIVE

HL



PERSPECTIVE

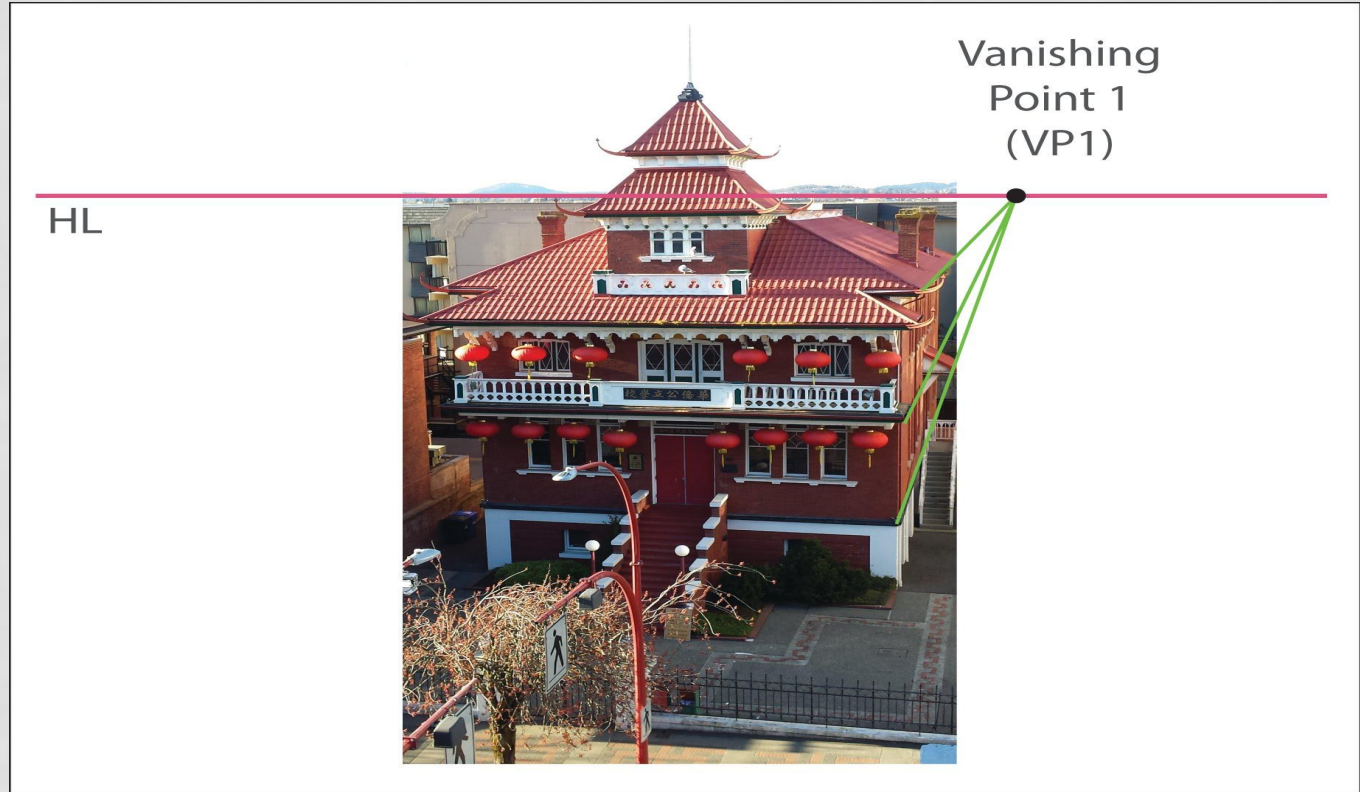

PERSPECTIVE

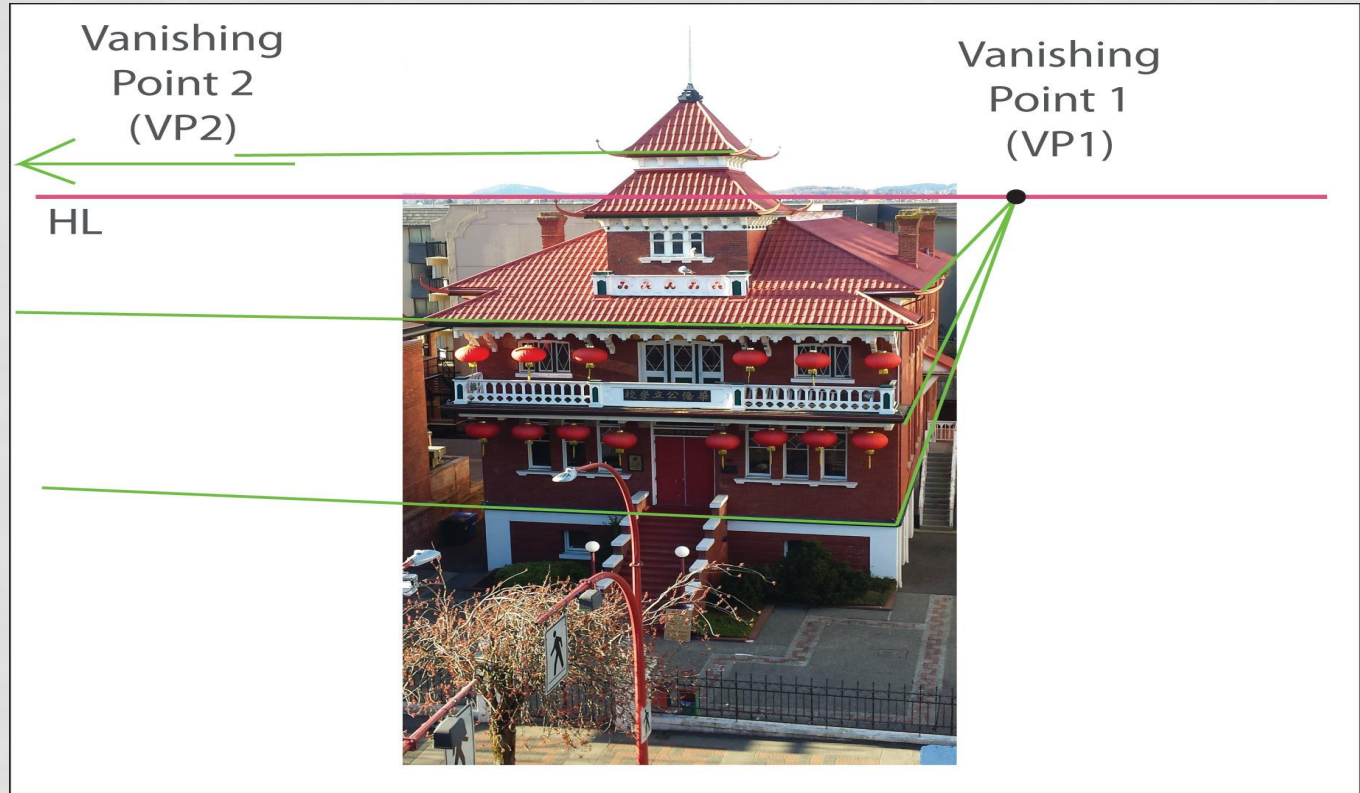

PERSPECTIVE EXERCISE

- From one selected photo (Perspective):
 - Draw perspective view on your sketch paper (omit details!)
 - Find Horizon Line = Eye Level
 - Start with first side (e.g. North or East elevation)
 - Find Vanishing Point 1 for this side (top line meets Eye Level)
 - Connect more construction lines to Vanishing Point

PERSPECTIVE EXERCISE

- From one selected photo (Perspective):
 - Continue from previous sketch:
 - Repeat for Vanishing Point 2 for the other side (plane)
 - Are there other (parallel) planes that share VP1 or VP2?

PERSPECTIVE



1 - POINT PERSPECTIVE

PERSPECTIVE



PARALLEL PLANES → SAME VANISHING POINT!

PERSPECTIVE

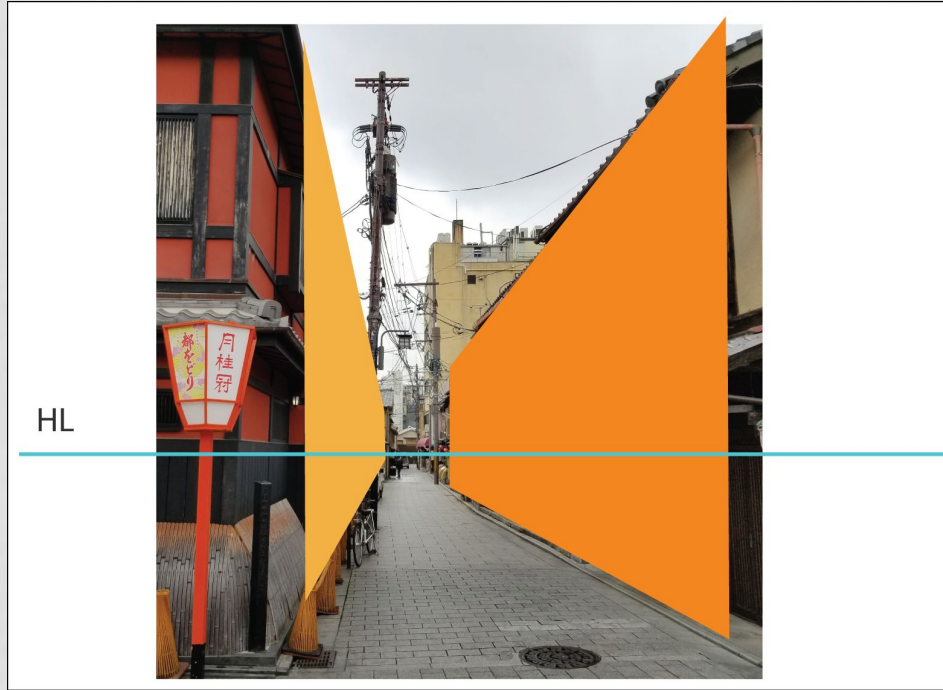

FIND HORIZON LINE (= EYE LEVEL)

PERSPECTIVE

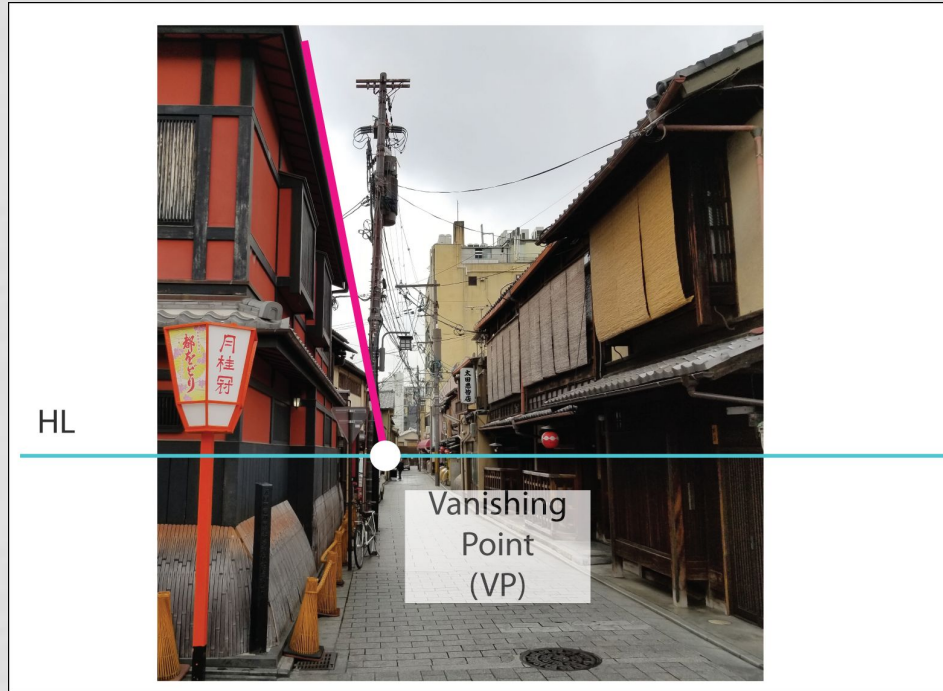

FIND VANISHING POINT

PERSPECTIVE

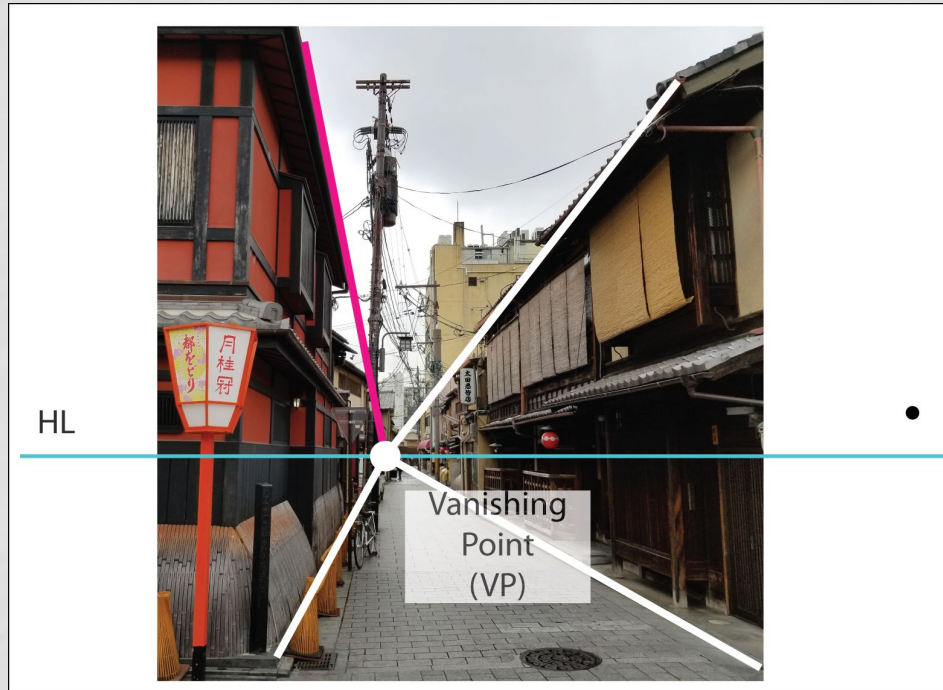

VANISHING LINES MEET AT SINGLE VP

PERSPECTIVE

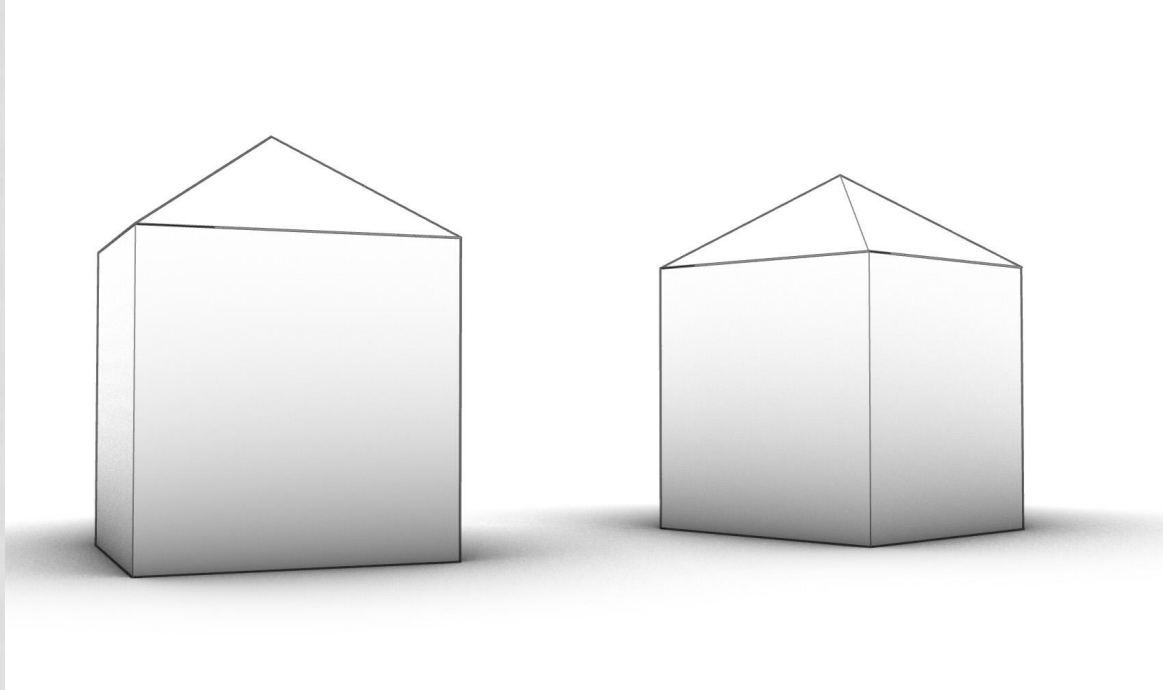

FORESHORTENING

PERSPECTIVE

- Is the observer standing or sitting?

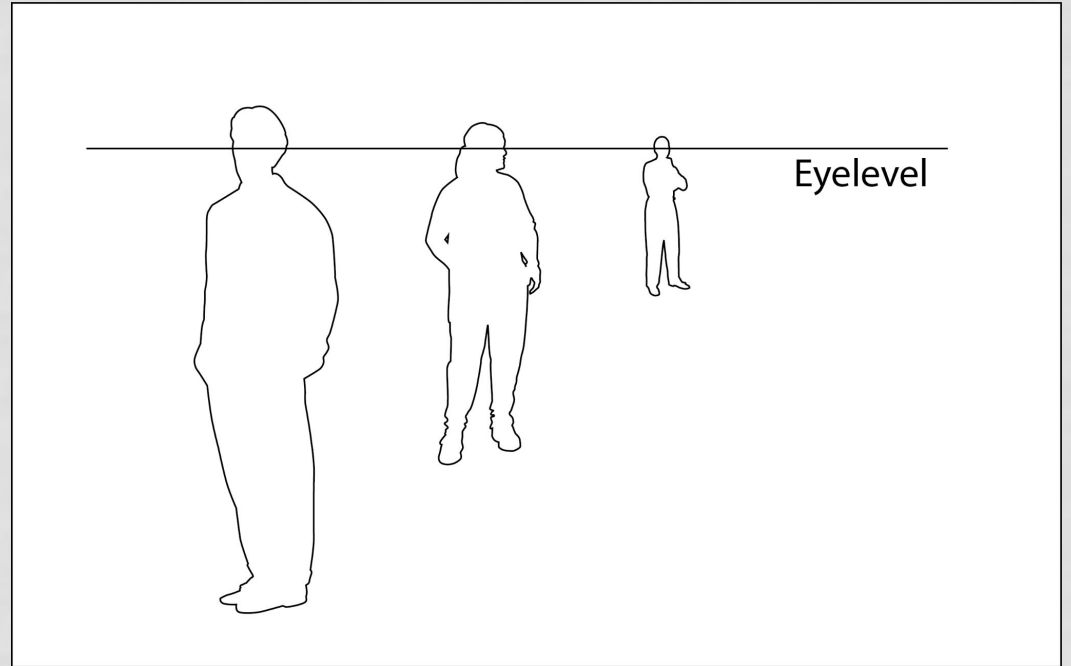

PERSPECTIVE

- Is the observer standing or sitting?

